

inspectabridge™

HP35



OUR MOST POPULAR MODEL

The HP35 has an extended platform length of 35ft. and provides 1400sq.ft. of under-bridge area from a fixed point on the bridge deck.



SMALL-SIZED TRAILER MODEL

FEATURES

- Single lane 5 minute deployment
- Self-propelled hydraulic drive
- Patented Tower Separation System
- Access crossover to tower remains horizontal at all times
- ± 5° Tower adjustment for super elevation
- Operator activated communication system at the main control panel; voice activated communication system at the platform
- 18 HP V-twin gas engine with auto idle as main hydraulic system
- Motor and hydraulic pump as auxiliary hydraulic backup system
- Hydraulic control panels: deck, platform and handheld
- Fall protection anchorage points
- Electric brakes standard

*From bottom of turntable side tube
** 4'-1" [1.24m] with platform parallel to bridge

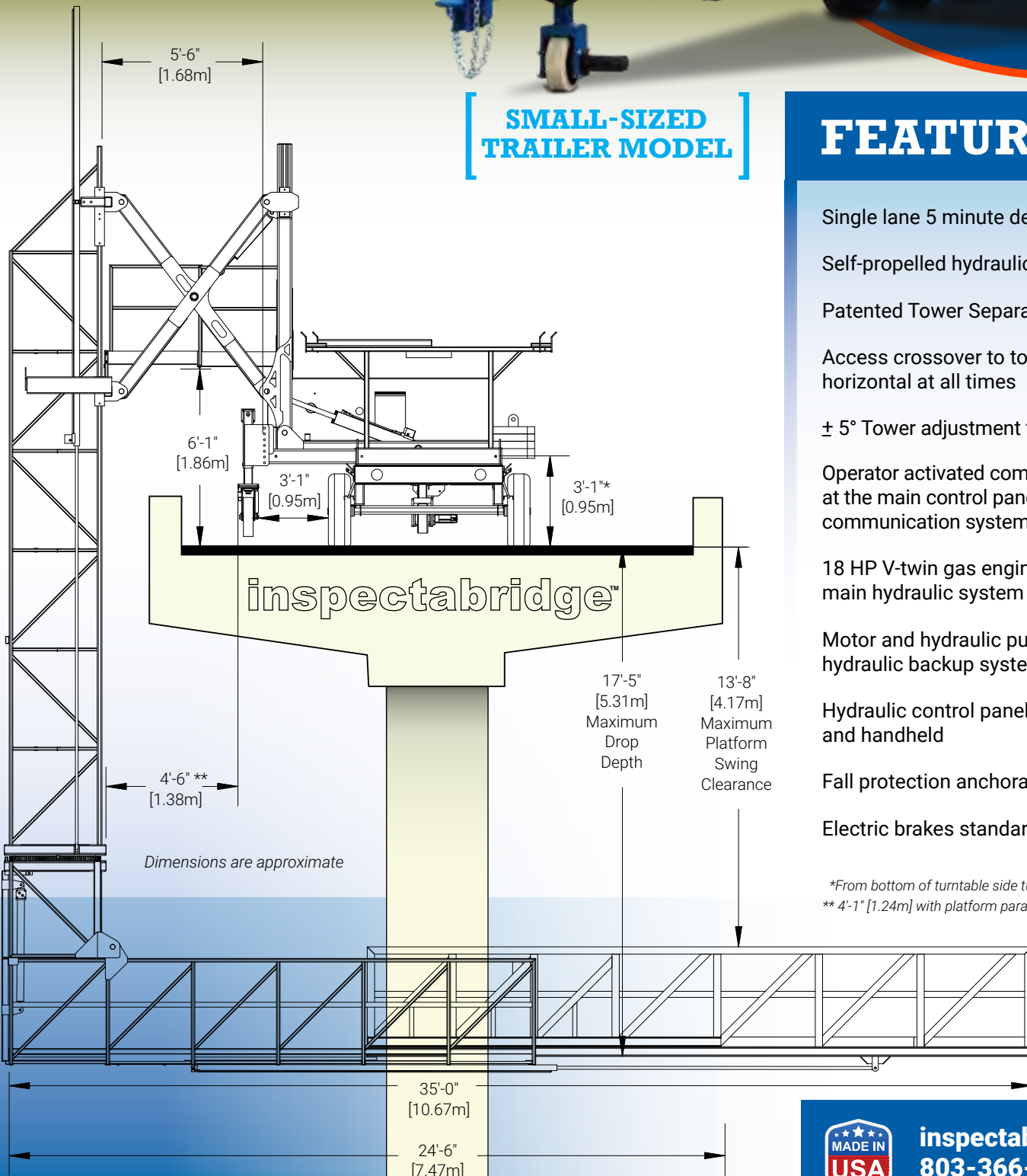

inspectabridge.com
803-366-8195

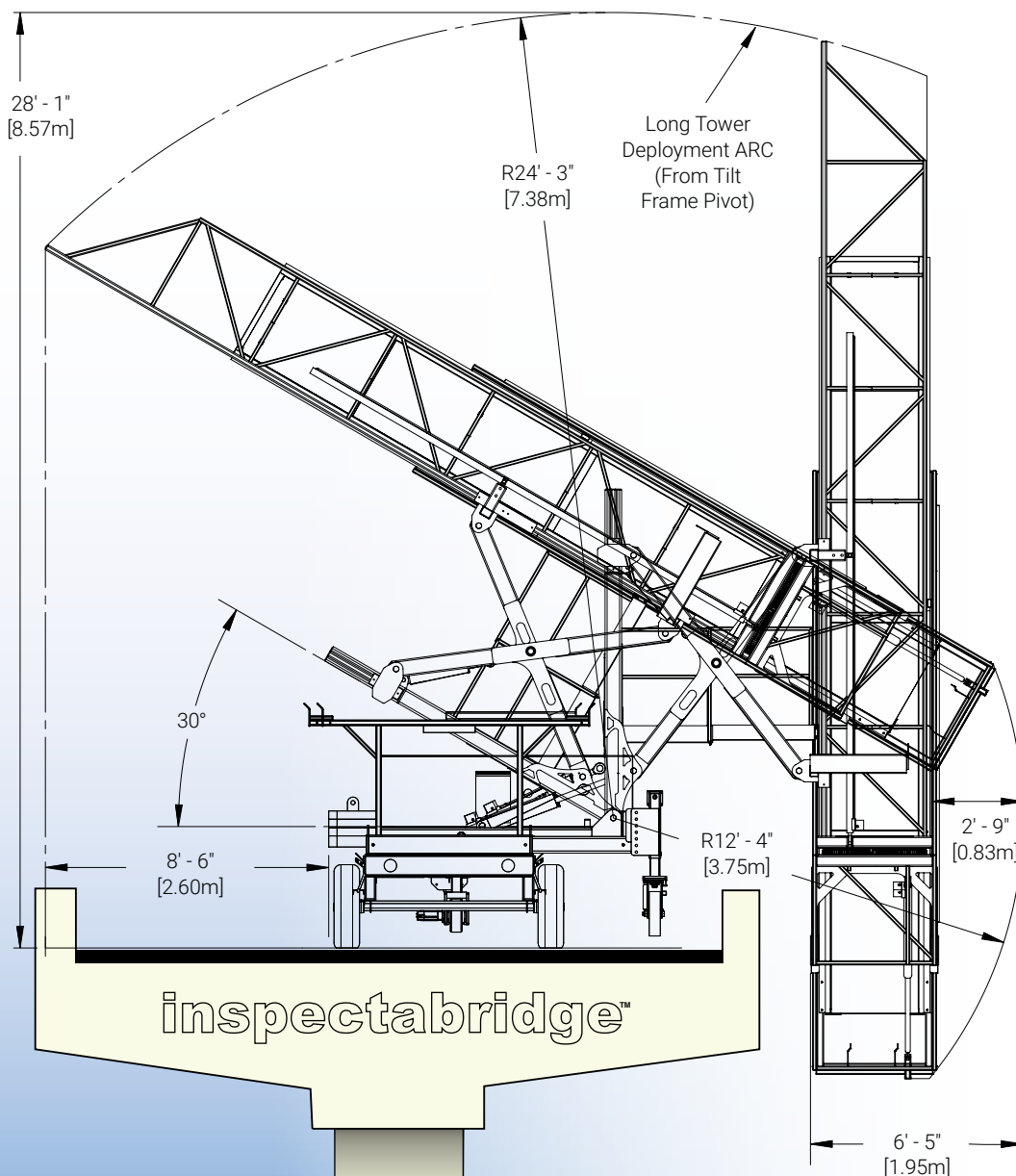

Dimensions are approximate

SPECS

| | US | METRIC |
|-----------------------------|------------|---------|
| Platform Length | 35ft | 10.67m |
| Platform Width - I.D. Alum. | 2ft - 7in | .79m |
| Platform Width - I.D. Steel | 3ft - 1in | .94m |
| Crossover Height Clearance | 6ft - 1in | 1.86m |
| Maximum Lowering Depth | 17ft - 5in | 5.31m |
| Tower Separation Width | 5ft - 6in | 1.68m |
| Total Weight (Approximate) | 18,600lbs | 8,436kg |
| Platform Weight Capacity | 1,000lbs | 454kg |
| Platform Rotation | 180° | |
| Maximum Grade | 5% (3°) | |
| Maximum Super Elevation | 8% (4.5°) | |
| Standards Compliance | ANSI A92.8 | |

| TRAVEL POSITION SPECIFICATIONS | | |
|--------------------------------|------------|-------|
| Unit Length | 31ft - 6in | 9.61m |
| Unit Width | 8ft - 4in | 2.54m |
| Unit Height | 11ft - 0in | 3.36m |

180° Platform Rotation

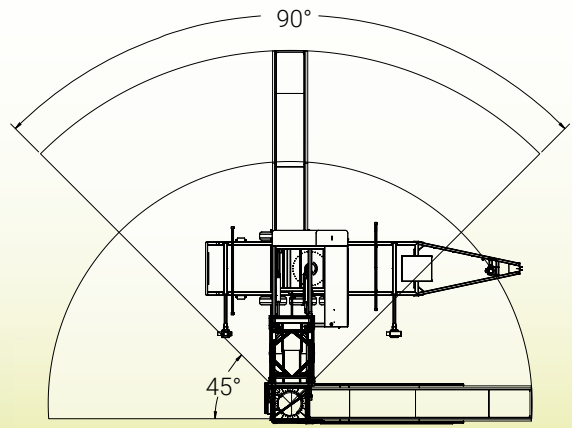

Our Patented Tower Separation System

Enables operators to erect and extend the tower & platform over sidewalks and other barriers without restricting under-bridge operations.

