

HP35

35 FEET OF EXTENDED REACH

The HP35 has an extended platform length of 35 ft. and provides more than 1,100 sq. ft. of under-bridge area from a fixed point on the bridge deck.



TRAILER MODEL

Available for: Rent Purchase

FEATURES

- Single-lane 5-minute deployment
- Self-propelled hydraulic drive
- Access crossover to tower remains horizontal at all times
- $\pm 5^\circ$ Tower adjustment for super elevation
- Operator-activated communication system at the main control panel; voice-activated communication system at the platform
- 19HP gas engine with an auto idle to power the main hydraulic system
- CANbus control system with 7" main panel display
- Multiple control locations
- Wireless remote with proportional paddles
- Level-sensing and load-sensing with visual and audible alarms
- Automatic outriggers
- Fall arrest anchor points

* From bottom of turntable side tube

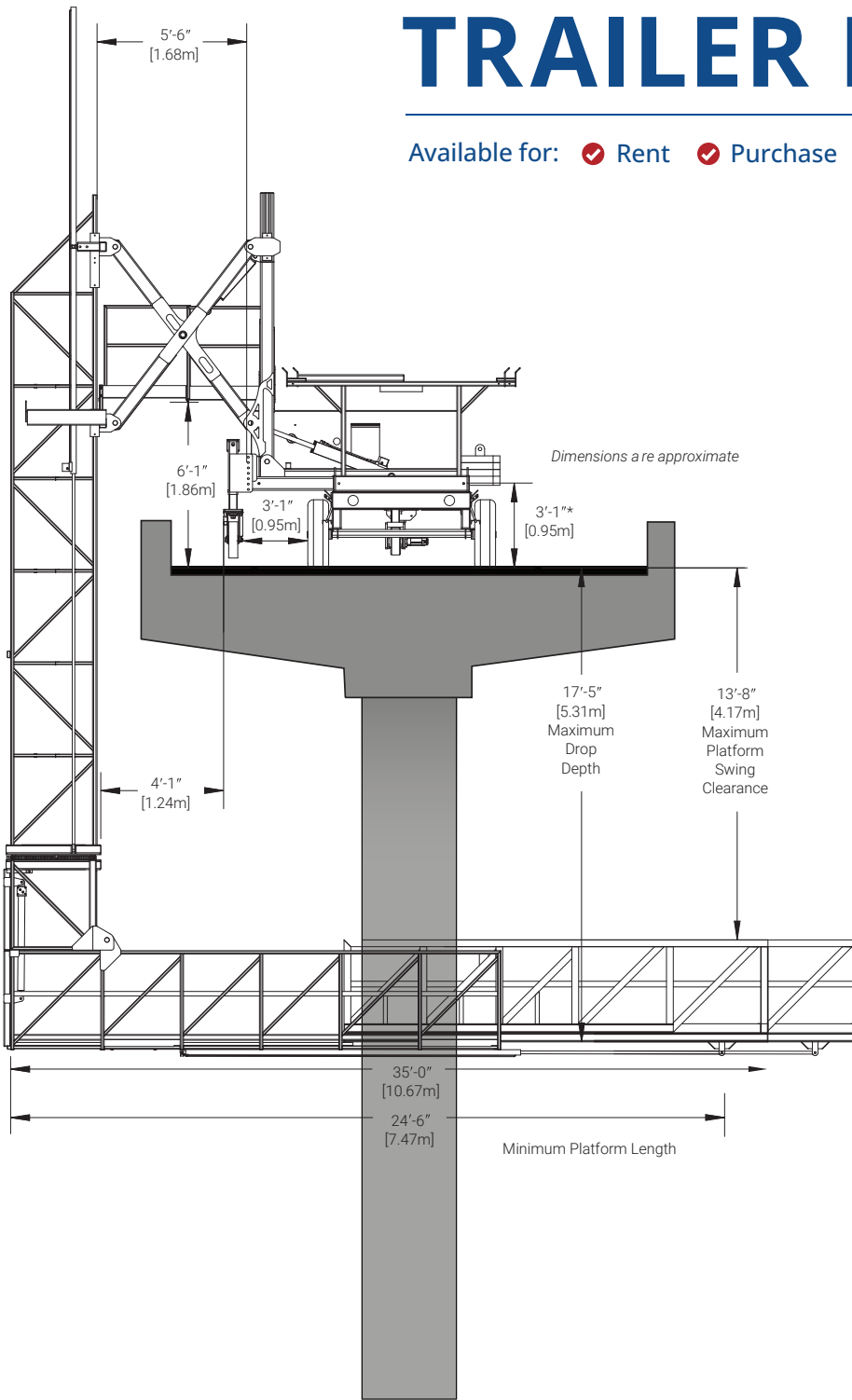

HP35

OUR TOWER SEPARATION SYSTEM

Enables operators to erect and extend the tower and platform over sidewalks and other barriers without restricting under-bridge operations.

180° DEGREE PLATFORM ROTATION

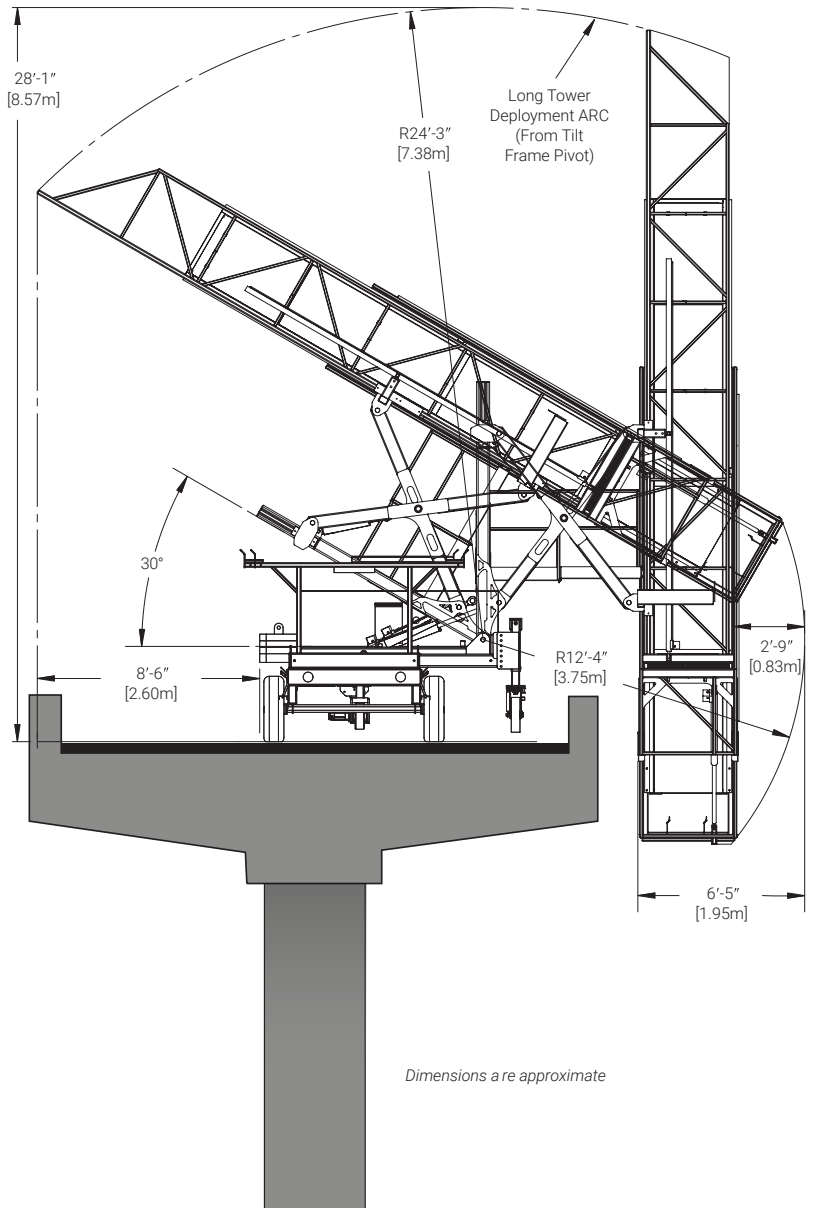
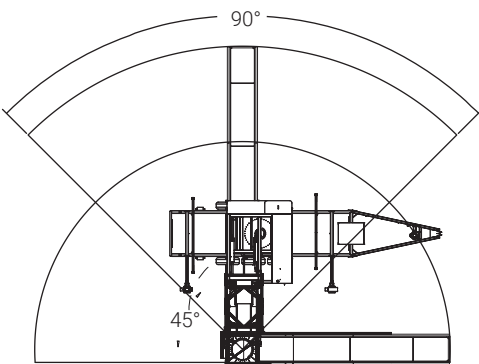

SPECS

■ Platform Length	35ft / 10.67m	■ Transport Width	8ft 4in / 2.54m
■ InsideSteel Platform Width	37in / .94m	■ Transport Height	11ft / 3.35m
■ Lowering Depth	17ft 5in / 5.31m	■ Weight, Unladen	18,900 lbs / 8.573 kg
■ Platform Capacity	1,000 lbs / 454 kg	■ Tongue Weight, Level Chasis	1,250 lbs / 567 kg
■ Capacity at End of Platform	500 lbs / 227 kg	■ Operating Wind Speed	28 mph / 12.5 m/s
■ Number of Occupants	5	■ Superelevation Slope	5°
■ Operating Hydraulic Pressure	2,800 psi / 193 bar	■ Grade Slope	4.5°